

Sit back. Relax. Stay warm.



Patio Heater Instruction Manual

Model#: FSD-A

Item #: PH-100083 GY



DANGER

FOR YOUR SAFETY: If you smell gas:
1. Shut off gas to the appliance.
2. Extinguish any open flame.
3. If odor continues, keep away from the appliance and immediately call your gas supplier or fire department.

DANGER

DANGER indicates an imminently hazardous situation which, if not avoided, will result in death or serious injury.

DANGER

Failure to comply with the precautions and instructions provided with this heater can result in death, serious bodily injury and property loss or damage from hazards of fire, explosion, burn, asphyxiation, and/or carbon monoxide poisoning. Only persons who can understand and follow the instructions should use or service this heater.

WARNING

This product can expose you to chemicals including Carbon Monoxide, Lead, Chromium (hexavalent compounds), Di(2-ethylhexyl) phthalate (DEHP) and Diisononyl phthalate (DINP), which are known to the State of California to cause cancer and birth defects or other reproductive harm. For more information, go to www.P65Warnings.ca.gov.

WARNING

Do not store or use gasoline or other flammable vapors and liquids in the vicinity of this or any other appliance. An LP cylinder not connected for use shall not be stored in the vicinity of this or any other appliance.

WARNING

Improper installation, adjustment, alteration, service or maintenance can cause property damage, injury or death. Read the installation, operation and maintenance instructions thoroughly before installing or servicing this equipment.

WARNING

FOR OUTDOOR USE ONLY!

ATTENTION

If your patio heater model is equipped with a base weight/sand box, it is strongly recommended that you fill it with sand or fine gravel and attach it securely to the bottom of the heater. In windy conditions, store the heater in a protected area or otherwise secure it. Unsecured heaters can be blown over in moderate to high wind. Damage due to weather or acts of God is not covered under warranty.



ATTACH YOUR RECEIPT HERE

Keep a copy of purchase or order confirmation which will be needed if you need to contact us about warranty coverage.

Serial No. _____

Purchase Date _____



**Electronic ignition.
Requires (1) AA Battery.
(Not Included)**



Questions, problems, missing parts?

Before returning to your retailer, our exceptional customer service is available.

Call us toll-free at **(800) 561-5550** – Friday 7:30 a.m. – 4 p.m., PST, email us at customer@jrhome.com



TABLE OF CONTENTS

Before You Begin	Page 2
Safety Information	Page 3
Package Contents	Page 4
Hardware Contents	Page 4
Assembly	Page 5-8
Operating Instructions	Page 9-12
Care and Maintenance	Page 13
Troubleshooting	Page 14
Warranty Information	Page 15

BEFORE YOU BEGIN

Please read and understand this entire manual before attempting to assemble, operate or install this appliance. If you have any questions regarding the product, please contact us.

This manual contains important information about the assembly, operation and maintenance of this patio heater. General safety information is presented in the first few pages and is also located throughout this manual. Keep this manual for future reference and to educate new users of this appliance. This manual should be read in conjunction with the labeling on the appliance. Safety precautions are essential when any mechanical or propane-fueled equipment is involved. These precautions are necessary when using, storing, and servicing. Using this appliance with the respect and caution demanded will reduce the possibilities of personal injury or property damage. The symbols shown in the "Safety Information" section are used extensively throughout this manual. Always heed these precautions, as they are essential when using any mechanical or propane-fueled equipment.



DANGER

DANGER indicates an imminently hazardous situation which, if not avoided, will cause death or serious injury.

DANGER

EXPLOSION—FIRE HAZARD

- Keep solid combustibles, such as building materials, paper, or cardboard a safe distance away from the heater as recommended by the instructions.
- Provide adequate clearances around air openings into the combustion chamber.
- Never use the heater in spaces which do or may contain volatile or airborne combustibles, or products such as gasoline, solvents, paint thinner, dust particles, or unknown chemicals.
- During operation, this appliance can be a source of ignition. Keep heater area clear and free from combustible materials, gasoline, paint thinner, cleaning solvents and other flammable vapors and liquids. Do not use heater in areas with high dust content. Minimum heater clearances from combustible materials: 3 feet (36 inches) from top and 2 feet (24 inches) from sides.
- Never store propane near high heat, open flames, pilot lights, direct sunlight, other ignition sources or where temperatures exceed 120° F (49° C).
- Propane vapors are heavier than air and can accumulate in low places. If you smell gas, leave the area immediately.
- Never install or remove a propane cylinder while the heater is lighted, near flame, pilot lights, or other ignition sources or while heater is hot to the touch.
- This heater is red hot during use and can ignite flammables too close to the burner. Keep flammables at least 3 feet (36 inches) from top and 2 feet (24 inches) from sides. Keep gasoline and other flammable liquids and vapors well away from heater.
- Store the propane cylinder outdoors in a well ventilated space out of the reach of children. Never store the propane cylinder in an enclosed area (house, garage, etc.). If heater is to be stored indoors, disconnect the propane cylinder for outdoor storage.

DANGER

CARBON MONOXIDE HAZARD

- This heater is a combustion appliance. All combustion appliances produce carbon monoxide (CO) during the combustion process. This product is designed to produce extremely minute, non-hazardous amounts of CO if used and maintained in accordance with all warnings and instructions. Do not block the air flow into or out of the heater.
- Carbon Monoxide (CO) poisoning produces flu-like symptoms, water eyes, headaches, dizziness, fatigue, and possibly death. You can't see and you can't smell it. It is an invisible killer. If these symptoms are present during operation of this product, get fresh air immediately!
- For outdoor use only.
- Never use inside house or other unventilated or enclosed areas.
- This heater consumes air (oxygen). Do not use in unventilated or enclosed areas to avoid endangering your life.

WARNING

WARNING indicates an imminently hazardous situation which, if not avoided, can result in death or serious injury.

WARNING

BURN HAZARD

- Never leave heater unattended when hot or in use.
- Keep out of reach of children.

WARNING

Certain materials or items, when stored under the heater, will be subject to radiant heat and could be seriously damaged.

WARNING: FOR OUTDOOR USE ONLY

CARBON MONOXIDE HAZARD

This appliance can produce carbon monoxide which has no odor. Using it in an enclosed space can kill you. Never use this appliance in an enclosed space such as a camper, tent or home.

WARNING

- This product is fueled by propane gas. Propane gas is invisible, odorless, and flammable. An odorant is normally added to help detect leaks and can be described as having a "rotten egg" smell. The odorant can fade over time so leaking gas is not always detectable by smell alone.
- Propane gas is heavier than air and leaking propane will sink to the lowest level possible. It can ignite by ignition sources including matches, lighters, sparks or open flames of any kind many feet away from the original leak. Use only propane gas set up for vapor withdrawal.
- Store to use propane gas in compliance with local ordinances and codes or with ANSI/NFPA 58. Turn off propane when not in use.
- Alert children and adults to the hazards of high surface temperatures. Stay away from these surfaces to avoid burning skin or igniting clothing.
- Carefully supervise young children when in the vicinity of the heater.
- Do not hang clothing or any other flammable materials from the heater, or place near the heater.
- Replace any guard or protective device removed for servicing the appliance prior to placing back in service.
- Installation and repair should be done by a qualified service person. The heater should be inspected before use and annually by a qualified service person. More frequent cleaning may be required as necessary. It is imperative that the control compartment, burners, and circulating air passageway of the appliance be kept clean.

CAUTION

CAUTION indicates an imminently hazardous situation which, if not avoided, may result in minor or moderate personal injury, or property damage.

CAUTION

SERVICE SAFETY

- Keep all connections and fittings clean. Make sure propane cylinder valve outlet is clean.
- During set up, check all connections and fittings for leaks using soapy water, never use a flame to check for leaks.
- Use as a heating appliance only. Never alter in any way to use with any device.

PACKAGE CONTENTS

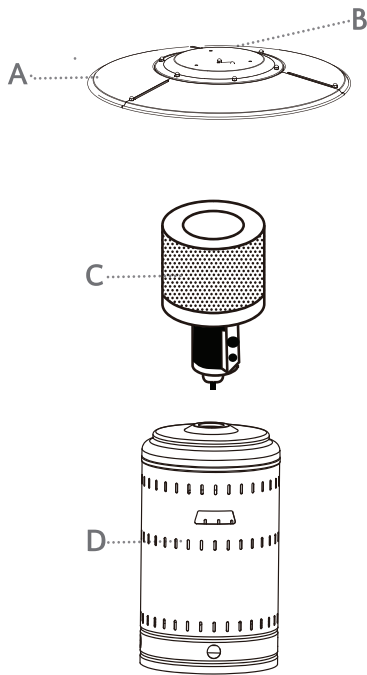

PART	DESCRIPTION	QUANTITY
A	Reflector Panel	3
B	Reflector Center Cap	1
C	Head Assembly	1 packed in 1 inner carton
D	Tank Housing	1
E	Gas Hose	1 attached to Head Assembly
F	Upper Post	1
G	Lower Post	1
H	Regulator	1 packed in inner carton
I	Post Supports	3 packed in 1 inner carton
J	Base	1
K	Wheel Assembly	1 packed in inner carton
L	Belt (secures LPG cylinder)	1 packed with post supports

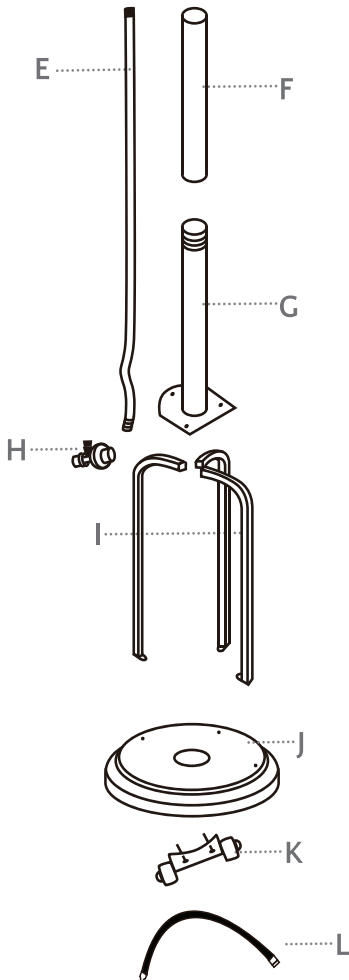

HARDWARE

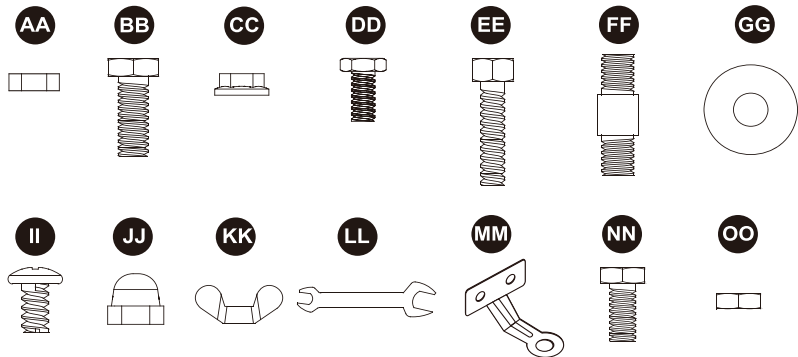

Item	Description	Qty
AA	M8 Flange Nut (packed with part I)	2
BB	Bolt M8x16 (2pcs packed with part I)	5
CC	M6 Flange Nut	6
DD	Stainless Steel Bolt (pre-assembled on part C)	4
EE	Bolt M6x30	6
FF	Reflector Spacer	3
GG	Washer	9
II	Screw M6x10	9
JJ	Cap Nut	9
KK	Wing Nut	3
LL	Wrench	1
MM	Anchoring Arm	3
NN	Bolt M6x10	6
OO	M6 Nut	6

PREPARATION





Before beginning assembly of this appliance, make sure all parts are present. Compare all parts with package contents list and hardware contents as listed on page 4 of this manual. If any part is missing or damaged, do not attempt to assemble this product. Contact Customer Service for replacement parts.

ESTIMATED ASSEMBLY TIME: 30 minutes

Tools Required for Assembly (NOT included):

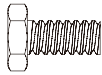
- Phillips screwdriver w/medium blade
- Leak test solution (see page 10)

1 Attach **Wheel Assembly (K)** to **Base (J)**. Align holes in **Wheel Assembly** with corresponding holes in **Base**, and insert 2 **M8x16 Bolts (BB)** through the holes and hand-tighten 2 **M8 nuts (AA)**. Be sure that the **Wheel Assembly** is parallel to the **Base (J)** and tighten with the **Wrench**. Attach 3pcs **anchoring arm (MM)** to base (H) using 6pcs **M6 nuts (OO)** and 6pcs **bolt M6x10 (NN)**.

- | | | | |
|-----------|---------------|---|-----|
| AA | M8 Flange nut |  | x 2 |
| BB | Bolt M8x16 |  | x 2 |
| MM | Anchoring Arm |  | x 3 |
| NN | Bolt M6x10 |  | x 6 |
| OO | M6 Nut |  | x 6 |

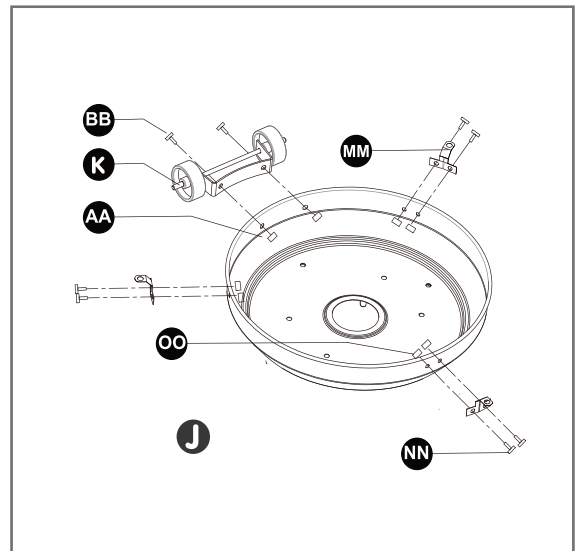

2 Attach the **Post Supports (1)** to the **Base (J)**. Align the holes in the bottom of each **Post Support** with the hole on the **Base**. Insert 1 **M8x16 Bolt (BB)** through the hole in the support and into the **Base** and hand-tighten. Repeat with the other 2 **Post Supports** and then tighten all **Bolts** with the **Wrench**.

- | | | | |
|-----------|------------|---|-----|
| BB | Bolt M8x16 |  | x 3 |
|-----------|------------|---|-----|

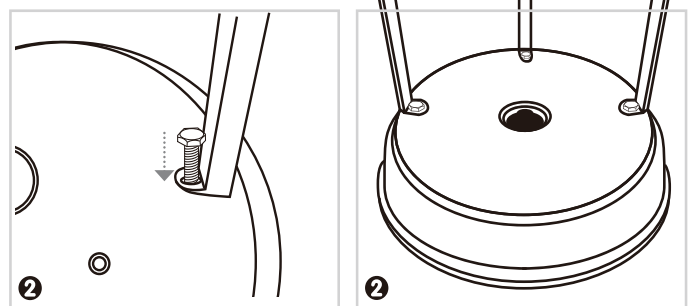

3 Attach the **Lower Post** **G** to the **Post Supports** **I**. Once you have tightened the bolts holding the **Post Supports** **I** to the **Base** **J**, align the holes in the **Lower Post** **G** with the holes on the tops of the **Post Supports** and insert a **M6x30 Bolt** **(EE)** through the hole in the **Post Support**. Secure with a **M6 nut** **(CC)**. Repeat this in the 5 remaining holes (6 holes total— 2 for each **Post Support** piece). Hand-tighten initially then tighten with the **Wrench** when all **Bolts** have been inserted.

CC M6 Flange nut  x 6

EE Bolt M6x30  x 6

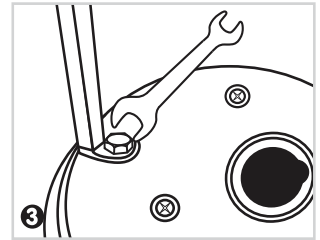
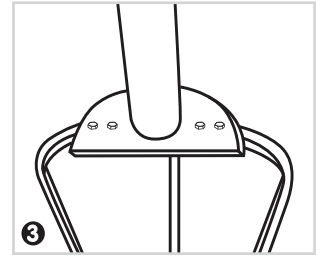
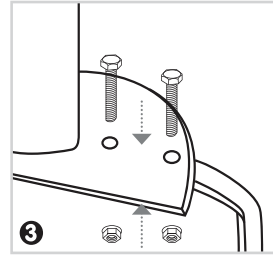

4 Attach **Upper Post** **F** to **Lower Post** **G** by screwing the two pieces of the post together.

5 Slide **Tank Housing** **D** over the assembled **Upper/Lower Posts** **F/G** and down over the **Post Supports** **I**. Rest the **Tank Housing** on the **Base** **J**.

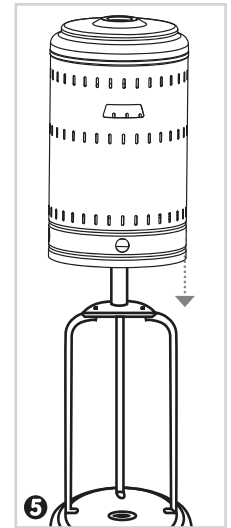
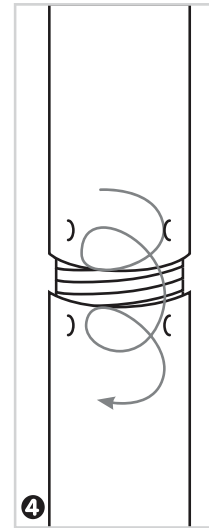

6 Attach the **Reflector Spacers** to the top of the **Head Assembly** **C**. Insert 1 **Reflector Spacer** **(FF)** through 1 **Washer** **(GG)** and into the hole on top of the **Head Assembly** **C**. Tighten stud securely. Repeat with the other 2 **Reflector Spacer**.

FF Reflector spacer  x 3

GG Washer  x 3

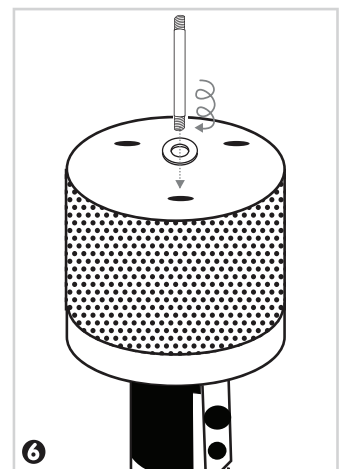



7 Attach **Head Assembly (C)** to **Upper Post (F)**: Loosen or remove the **4 Bolts (DD)** pre-installed in the neck of the **Head Assembly**. Route **Gas Hose (B)** down into **Upper/Lower Posts (F/G)** and align 4 small holes on the **Head Assembly (C)** with 4 small holes in the **Upper Post (F)**. Insert **4 Bolts** through the aligned 4 holes and tighten securely with wrench.

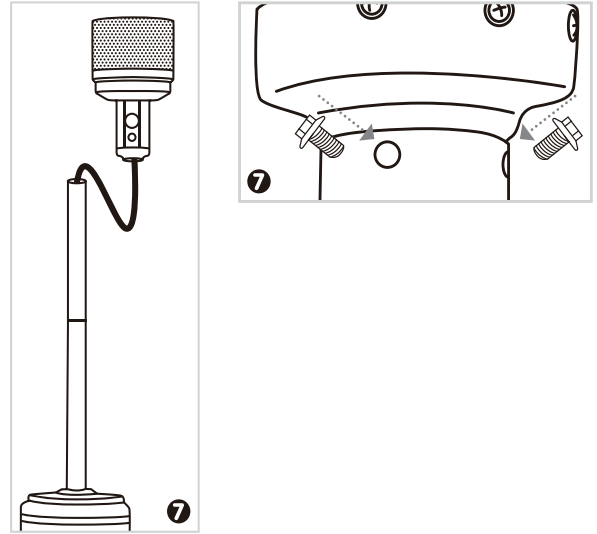

8 Install Reflector. **NOTE: MAKE SURE TO REMOVE PROTECTIVE PLASTIC COVER ON REFLECTOR PIECES PRIOR TO ASSEMBLY!**

Assembly Tip: If necessary for proper alignment of reflector sections, loosen each screw prior to further assembly and retighten after sections are aligned.

Slide two **Reflector Panels (A)** together. Insert one **Screw (II)**. Screw on **Cap Nut (JJ)** loosely.

Repeat with the other **Reflector Panels (A)**.

Slide **Reflector Center Cap (B)** onto assembled **Reflector Panels (A)**. Insert one **Screw (II)** and screw on **Cap Nut (JJ)** loosely. Repeat with 2 more **Screws (II)** and **Cap Nuts (JJ)** to complete reflector assembly. Fully tighten all screws and cap nuts.

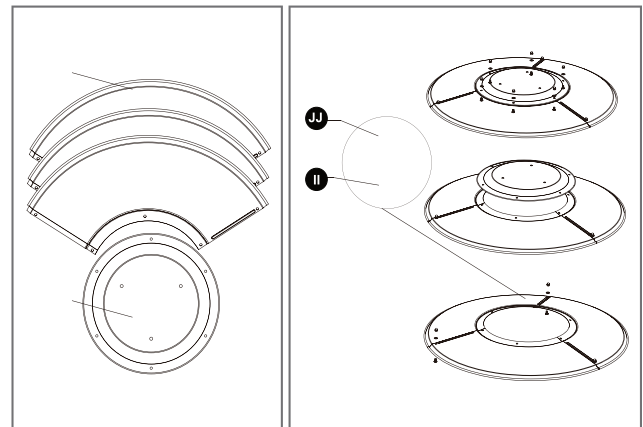



II Screw M6 X 10  x 9

JJ Cap nut  x 9



9 While supporting heater, tilt the **Head Assembly** **C** and slide 3 **Washers** (GG) over the **Reflector Spacers**. Place the **Reflector Assembly** onto **Reflector Spacers** and slide 3 **Washers** (GG) over the **Reflector Spacers** and onto the **Reflector Assembly**. Secure with 3 **Wing Nuts** (KK). Once you have tightened the **Wing Nuts**, return the heater to an upright position.

- GG** Washer  x 6
- KK** Wing nut  x 3

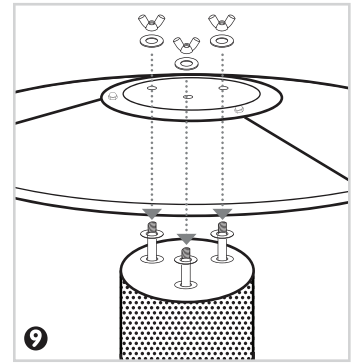
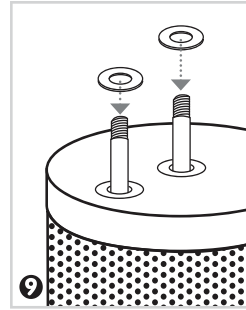

10 Connect the hose and regulator to the LPG tank. The LPG tank is sold separately. Use a standard 20 lb. propane tank *only*. Lift the **Tank Housing** **D** up and rest it on the top of the assembled **Post Supports** **I**. Screw **Regulator** **H** onto **Gas Hose** **E**. Do not cross thread. Attach the **Regulator** to the valve on the LPG tank and hand tighten securely. Place LPG tank onto base of heater. Secure the LPG tank by attaching the **Belt** **L** onto the post supports. Lower the **Tank Housing**.

NOTE: Use this heater only with a propane vapor withdrawal supply system. See chapter 5 of the standard for storage and handling of liquefied petroleum gas, ANSI/NFPA 58. Your local library or fire department should have this book.

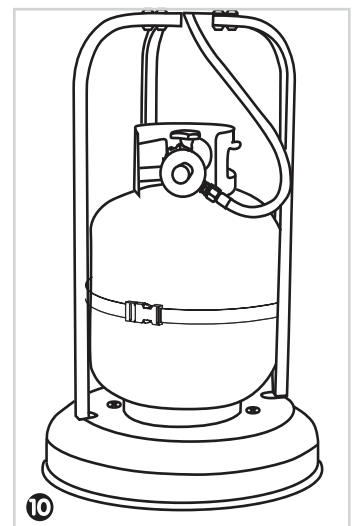
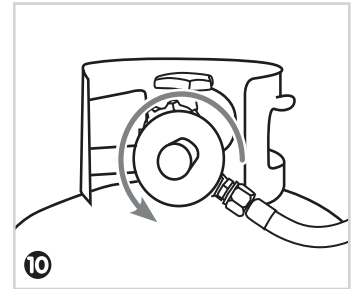
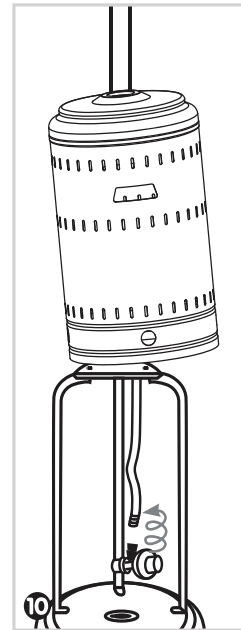



A minimum supply pressure of .5 psi is required for the purpose of input adjustment of propane gas. Storage of an appliance indoors is permissible only if the cylinder is disconnected and removed from the appliance. A cylinder must be stored outdoors in a well-ventilated area out of the reach of children. A disconnected cylinder must have dust caps tightly installed and must not be stored in a building, garage, or any other enclosed area. The minimum permissible gas supply pressure of 11 W.C. is required for purpose of hose adjustment. The minimum hourly of 17,500 BTU is required input rating for a heater for automatic operation rating less than full input rating.

The pressure regulator and hose assembly supplied with the appliance must be used.

The installation must conform with local codes, or in the absence of local codes, with national fuel gas code, ANSI Z223.1/NFPA54, natural gas and propane Installation Code, CSA B149.1, or propane storage and handling code, B149.2

A dented rusted or damaged propane cylinder may be hazardous and should be checked by your local cylinder supplier. Never use a propane cylinder with a damaged valve connection. The propane cylinder must be constructed and marked in accordance with the specifications for LPG tanks of the U.S. Department of Transportation (DOT) or the standard for cylinders, spheres and tubes for transportation of dangerous goods and commission, CAN/CSA-B339.

- Do not store a spare LP-gas cylinder under or near this appliance.
- Never fill the cylinder beyond 80 percent full.
- Place the dust cap on the cylinder valve outlet whenever the cylinder is not in use. Only install the type of dust cap on the cylinder valve that is provided with the cylinder valve. Other types of caps or plugs may result in leakage of propane.

- The cylinder must have a listed overfilling prevention device.
- The cylinder must have a connection device compatible with the connection for the appliance.
- The cylinder used must include a collar to protect the cylinder valve.
- Never connect an unregulated propane cylinder to the heater.



LEAK TEST

1. Make 2–3 oz. of leak test solution (one part liquid dish washing detergent and three parts water).
2. Apply several drops of solution where hose attaches to regulator.
3. Apply several drops of solution where regulator connects to cylinder.
4. Make sure all patio heater valves are OFF.
5. Turn cylinder valve ON.

WARNING

- Perform all leak tests outdoors.
- Extinguish all open flames.
- NEVER leak test when smoking
- Do not use heater until all connections have been leak tested and show no signs of leakage.

IF BUBBLES APPEAR AT ANY CONNECTION, THERE IS A LEAK.

1. Turn cylinder valve OFF.
2. If leak is detected at hose/regulator connection, tighten connection and perform another leak test. If bubbles continue to appear, call our customer service desk.
3. If leak is detected at regulator/cylinder valve connection, disconnect, reconnect, and perform another leak test. If you continue to see bubbles after several attempts, cylinder valve is defective. Call our customer service desk.

IF NO BUBBLES APPEAR AT ANY CONNECTION, THE CONNECTIONS ARE SECURE.

Note: Whenever gas connections are loosened or removed, you must perform a complete leak test.

WARNING: **FOR OUTDOOR USE ONLY**

CARBON MONOXIDE HAZARD

This appliance can produce carbon monoxide which has no odor. Using it in an enclosed space can kill you. Never use this appliance in an enclosed space such as a camper, tent or home.

Caution: Do not attempt to operate this appliance until you have read and understand all Safety Information in this manual and all assembly is complete and leak tests have been performed.

BEFORE TURNING GAS SUPPLY ON:

1. Your heater was designed and approved for **OUTDOOR use only**. Do NOT use it inside a building, garage, or any other enclosed area.
2. Make sure surrounding areas are free of combustible materials, gasoline, and other flammable vapors or liquids.
3. Ensure that there is no obstruction to air ventilation. Be sure all gas connections are tight and there are no leaks.
4. Be sure the cylinder cover is clear of debris. Be sure any component removed during assembly or servicing is replaced and fastened prior to starting.

BEFORE LIGHTING:

1. Heater should be thoroughly inspected before each use, and by a qualified service person at least annually. If re-lighting a hot heater, always wait at least 5 minutes.
2. Inspect the hose assembly for evidence of excessive abrasion, cuts, or wear. Suspected areas should be leak tested. If the hose leaks, it must be replaced prior to operation. Only use the replacement hose assembly specified by the manufacturer.

OPERATING INSTRUCTIONS



Lighting:

Note: This heater is equipped with a pilot light that allows for safer startups and shutdowns. Pilot must be lit before main burner start.

1. Turn the control knob to the "OFF" position.
2. Fully open LP cylinder valve.
3. Open viewing hole by sliding cover to either side.
4. Push control knob in and rotate to "PILOT" position.

Note: For initial start or after any cylinder change, hold control knob in for 2 minutes to purge air from gas lines before proceeding.

5. Push and release the igniter button until pilot flame is lit and is visible through viewing hole.
6. Once the pilot is lit, continue to depress the control knob for 30 seconds.
7. If the pilot does not stay lit, repeat steps 4 to 6.

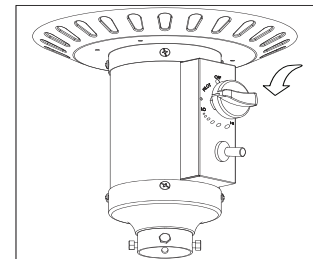
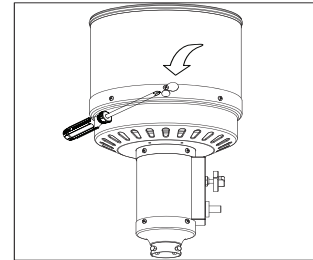
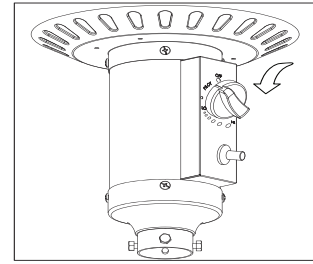

8. Turn the control knob to "LO" position to light the burner. Then press slightly and turn the control knob between "LO" and "HI" to get desired temperature.

Note: If pilot fails to remain lit, all valves should be closed and a waiting period of at least 5 minutes should pass before attempting to light

If you experience any ignition problem please consult "Troubleshooting".

Caution: Avoid inhaling fumes emitted from the heater's first use. Smoke and odor from the burning of oils used in manufacturing will appear. Both smoke and odor will dissipate after approximately 30 minutes. The heater should NOT produce thick black smoke.

Note: The burner may be noisy when initially turned on. To eliminate excessive noise from the burner, turn the control knob to the PILOT position. Then, turn the knob to the level of heat desired.

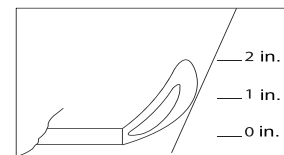
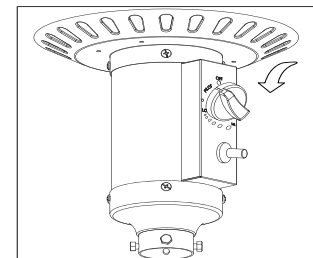

Normal

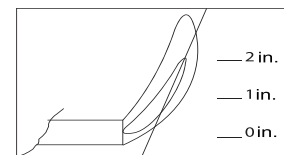

Abnormal



OPERATION CHECKLIST:

For a safe and pleasant heating experience, perform this check before each use:

BEFORE OPERATING:

- I am familiar with entire owner's manual and understand all precautions noted.
- All components are properly assembled, intact and operable.
- No alterations have been made.
- All gas connections are secure and do not leak.
- Wind velocity is below 10 mph.
- Heater is for use outdoors (outside any enclosure).
- There is adequate fresh air ventilation.
- Heater is away from gasoline or other flammable liquids or vapors.
- Heater is away from windows, air intake openings, sprinklers and other water sources.
- Heater is at least 36 in. on top and at least 24 in. on sides from combustible materials.
- Heater is on a hard and level surface.
- There are no signs of spider or insect nests in heater orifices.
- All burner passages are clear.
- All air circulation passages are clear.
- Clothing or other protective material should not be hung from the heater, or placed on or near the heater.
- Any guard or other protective device removed for servicing the heater must be replaced prior to operating the heater.
- Installation and repair should be done by a qualified service person. The heater should be inspected before each use and at least annually by a qualified service person.

OPERATION INFORMATION AND SAFETY:

- Unit will operate at reduced efficiency below 40° F.
- Children and adults should be alerted to the hazards of high surface temperatures and should stay away to avoid burns or clothing ignition.
- Young children should be carefully supervised when they are in the area of the heater.
- More frequent cleaning may be required as necessary. It is imperative that control compartment burner and circulating air passageways of the heater be kept clean and free of debris and/or spider or insect nests.

WARNING

FOR YOUR SAFETY
Heater will be hot after use. Handle with extreme care.



SHUT DOWN:

1. Turn control knob clockwise to PILOT. (Normally, burner will make a slight popping sound when extinguished.) Burner will extinguish but PILOT will remain ON.
2. To extinguish PILOT, depress control knob and continue to turn it clockwise to OFF.
3. Turn cylinder valve clockwise to OFF and disconnect regulator when heater is not in use.

Note: After use, some discoloration of the emitter screen is normal.



AFTER OPERATION:

1. Gas control knob is in OFF position.
2. Gas tank valve is OFF.
3. Disconnect gas line.
4. Heater is stored upright in a secure location.



To enjoy years of outstanding performance from your heater, make sure you perform the following maintenance activities on a regular basis:

KEEP EXTERIOR SURFACES CLEAN.

1. Use soapy water for cleaning. Never use flammable or corrosive cleaning agents.
2. While cleaning your unit, be sure to keep the area around the burner and control compartment dry at all times. Do not submerge the control valve assembly. If the gas control is submerged in water, do NOT use it. It must be replaced.
3. Air flow must be unobstructed. Keep controls, burner, and circulating air passageways clean. Signs of possible blockage include:
 - Gas odor with extreme yellow tipping of flame.
 - Heater does NOT reach the desired temperature.
 - Heater glow is excessively uneven.
 - Heater makes popping noise.
 - Spiders and insects can nest in burner or orifices. This dangerous condition can damage heater and render it unsafe for use. Clean burner holes by using a heavy-duty pipe cleaner. Compressed air may help clear away smaller particles.
 - Carbon deposits may create a fire hazard. Clean dome and burner screen with warm soapy water if any carbon deposits develop.

Note: *In a salt-air environment (such as near an ocean), corrosion occurs more quickly than normal. Frequently check for corroded areas and repair them promptly.*

TIP FOR STAINLESS STEEL MODELS:

Use high-quality automobile wax to help maintain the appearance of your heater. Apply to exterior surfaces from the post down. DO NOT apply to emitter screen or domes.

WARNING

FOR YOUR SAFETY

- Do NOT touch or move heater for at least 45 minutes after use.
- Reflector is hot to the touch.
- Allow reflector to cool before touching.

STORAGE:

Between uses:

- Turn control knob OFF.
- Disconnect LP source.
- Store heater upright in an area sheltered from direct contact with inclement weather (such as rain, sleet, hail, snow, dust and debris).
- If desired, cover heater to protect exterior surfaces and to help prevent build-up in air passages. Never leave LPG tank exposed to direct sunlight or excessive heat.

Note: Wait until heater is cool before covering.

SERVICE:

Only a qualified service person should repair gas passages and associated components.

Caution: *Always allow heater to cool before attempting service.*



PROBLEM	POSSIBLE CAUSE	CORRECTIVE ACTION
<p>Pilot won't light</p> <p>Note: Heater operates at reduced efficiency below 40°F</p>	<ol style="list-style-type: none"> 1. Cylinder valve is closed 2. Blockage in orifice or pilot tube 3. Air in gas line 4. Low gas pressure with cylinder valve fully open 5. Igniter fails 	<ol style="list-style-type: none"> 1. Open valve 2. Clean or replace orifice or pilot tube 3. Open gas line and bleed it (pressing control knob in) for not more than 1 - 2 minutes or until you smell gas 4. Turn cylinder valve OFF and replace cylinder 5. Use match to light pilot; obtain new igniter and replace
Pilot won't stay lit	<ol style="list-style-type: none"> 1. Dirt built up around pilot 2. Connection between gas valve and pilot assembly is loose 3. Thermocouple is not operating correctly 	<ol style="list-style-type: none"> 1. Clean dirt from around pilot 2. Tighten connection and perform leak check 3. Replace thermocouple
Burner won't light	<ol style="list-style-type: none"> 1. Propane cylinder is frosted over 2. Blockage in orifice 3. Control knob is not in ON position 	<ol style="list-style-type: none"> 1. Wait until the propane cylinder warms up and becomes unfrosted 2. Clear blockage 3. Turn control knob to ON
Burner flame is low	<ol style="list-style-type: none"> 1. Gas pressure is low 2. Outdoor temperature is less than 40°F and tank is less than 1/4 full 3. Control knob fully ON 4. Spiders and insects nest in burner or orifices 	<ol style="list-style-type: none"> 1. Turn cylinder valve OFF and replace cylinder 2. Use a full cylinder 3. Check burner and orifices for blockage 4. Clean burner and orifices
Thick black smoke	<ol style="list-style-type: none"> 1. Blockage in burner 	<ol style="list-style-type: none"> 1. Remove blockage and clean burner inside and outside
Gas odor with extreme yellow tipping of flame.	<ol style="list-style-type: none"> 1. Spiders and insects nest in burner or orifices 	<ol style="list-style-type: none"> 1. Clean burner and orifices
Heater glow is excessively uneven.	<ol style="list-style-type: none"> 1. Spiders and insects nest in burner or orifices 	<ol style="list-style-type: none"> 1. Clean burner and orifices
Heater makes popping noises.	<ol style="list-style-type: none"> 1. Spiders and insects nest in burner or orifices 	<ol style="list-style-type: none"> 1. Clean burner and orifices
Carbon build-up	<ol style="list-style-type: none"> 1. Dirt or film on reflector and burner screen 	<ol style="list-style-type: none"> 1. Clean reflector and burner screen

IMPORTANT

For questions, concerns or problems with our product please email our customer service department:

customercare@jrhome.com

DATED PROOF OF PURCHASE REQUIRED FOR WARRANTY SERVICE

Si vous éprouvez des difficultés ou si vous avez des questions ou des préoccupations, prière de faire parvenir un courriel à notre service à la clientèle

customercare@jrhome.com

UNE PREUVE D'ACHAT DATÉE EST REQUISE POUR SE PRÉVALOIR DE LA GARANTIE.

WARRANTY

This product is inspected, tested and carefully packaged to minimize the chance of damage during shipment. If a part (excluding light bulbs, glass and fuses*) within one year from the date of purchase proves to be defective in material or fabrication under normal use, the part will be repaired or replaced. The Company's obligation under the warranty is to replace or repair defective parts at our discretion. Any expenses or damage resulting from the installation, removal or transportation of the product will be the responsibility of the owner and are not covered by this warranty. The owner assumes all other risks arising from the use or misuse of the product. The warranty will be void if the product damage or failure is deemed by the Company to be caused by accident, alteration, misuse, abuse, incorrect installation or removal, or connection to an incorrect power source by the owner. The Company neither assumes, nor authorizes any person or entity to assume for it any obligation or liability associated with its products. Light bulbs and fuses are not covered under this warranty. If you have any questions regarding the warranty or service, please contact us at **customercare@jrhome.com**.

Customer Service :

JR Home Products

Unit 306 - 19100 Airport Way, Pitt Meadows, BC V3Y 0E2

Toll Free : 1-800-561-5550

E-mail : **customercare@jrhome.com**

AVERTISSEMENT

Ce produit a été soigneusement inspecté, testé et emballé afin de minimiser les risques de dommages durant le transport. Si l'une des pièces (à l'exception des verres, des ampoules électriques et des fusibles*) s'avère défectueuse au niveau de sa fabrication ou de ses matériaux dans l'année qui suit la date de l'achat suite à une utilisation normale, la pièce sera réparée ou remplacée. La compagnie est tenue de réparer ou remplacer les pièces défectueuses à sa discrétion, en vertu de la garantie. Tous frais ou dommage résultant de l'installation, du démantèlement ou du transport du produit demeurent la responsabilité du client et n'est pas couvert par cette garantie. Le client assume tout autre risque résultant de l'utilisation correcte ou fautive du produit. La garantie devient nulle si la compagnie détermine que le dommage ou le mauvais fonctionnement est causé par un accident, une modification, une mauvaise utilisation, un abus, une mauvaise installation ou un mauvais démantèlement ou un branchement à une source électrique inadéquate de la part du client. La compagnie n'est pas responsable et n'autorise quiconque, personne ou entité légale, à accepter de responsabilité ou obligation en son nom, en rapport avec ses produits. * Les ampoules électriques et les fusibles ne sont pas couverts par cette garantie. Pour toute question au sujet de la garantie ou du service, contacter le service à la clientèle à : **customercare@jrhome.com**.

Service à la clientèle:

JR Home Products

Unit 306 - 19100 Airport Way, Pitt Meadows BC V3Y 0E2 Numéro

sans frais: 1-800-561-5550

Courriel: **customercare@jrhome.com**

You MUST register your product within 30 days of purchase to receive warranty service.

Registration can be completed online at www.jrhome.com or by mailing this form.

Vous DEVEZ enregistrer votre produit dans les 30 jours suivant l'achat pour bénéficier du service de garantie.

L'enregistrement sera complet une fois que vous aurez posté ce formulaire ou que vous serez inscrit en ligne.



Warranty Registration Information Form / Formulaire d'enregistrement de la garantie

Name / Nom : _____

Street / Adresse : _____

City / Ville : _____

Province / Province : _____

Postal Code / Code postal : _____

Daytime Phone # / No téléphone jour : _____

Evening Phone # / No téléphone soir : _____

E-Mail Address / Courriel : _____

Product/Produit : _____

Place of Purchase / Lieu de l'achat : _____

Date of Purchase / Date de l'achat : _____

Model # / No de modèle : _____

Serial # / Numéro de série : _____

You MUST register your product to receive warranty service.

For warranty service, contact J&R Home Products at the address, phone numbers listed below within 30 days of purchase. Be sure to have your sales receipt and original date of purchase. All warranty service will be coordinated by J&R Home Products service center.

Vous DEVEZ enregistrer votre produit pour vous prévaloir de la garantie.

Afin de faire valoir la garantie, communiquez avec J&R Home Products à l'adresse et aux numéros indiqués ci-dessous dans les 30 jours suivant la date d'achat. Ayez en main votre reçu et la date d'achat. Toutes les demandes liées aux garanties seront traitées par le centre de service de J&R Home Products.